

# MAH JONG

design Hans HOPFER

**rochebobo**  
PARIS



# MAH JONG

design Hans HOPFER

TISSUS DESIGN Kenzo Takada / FABRICS DESIGN Kenzo Takada / TELAS DISEÑO Kenzo Takada

rochebobois  
PARIS

COLLECTION MATSURI - Harmonie Umi / COLLECTION MATSURI - Umi Harmony / COLECCIÓN MATSURI - Armonía Umi

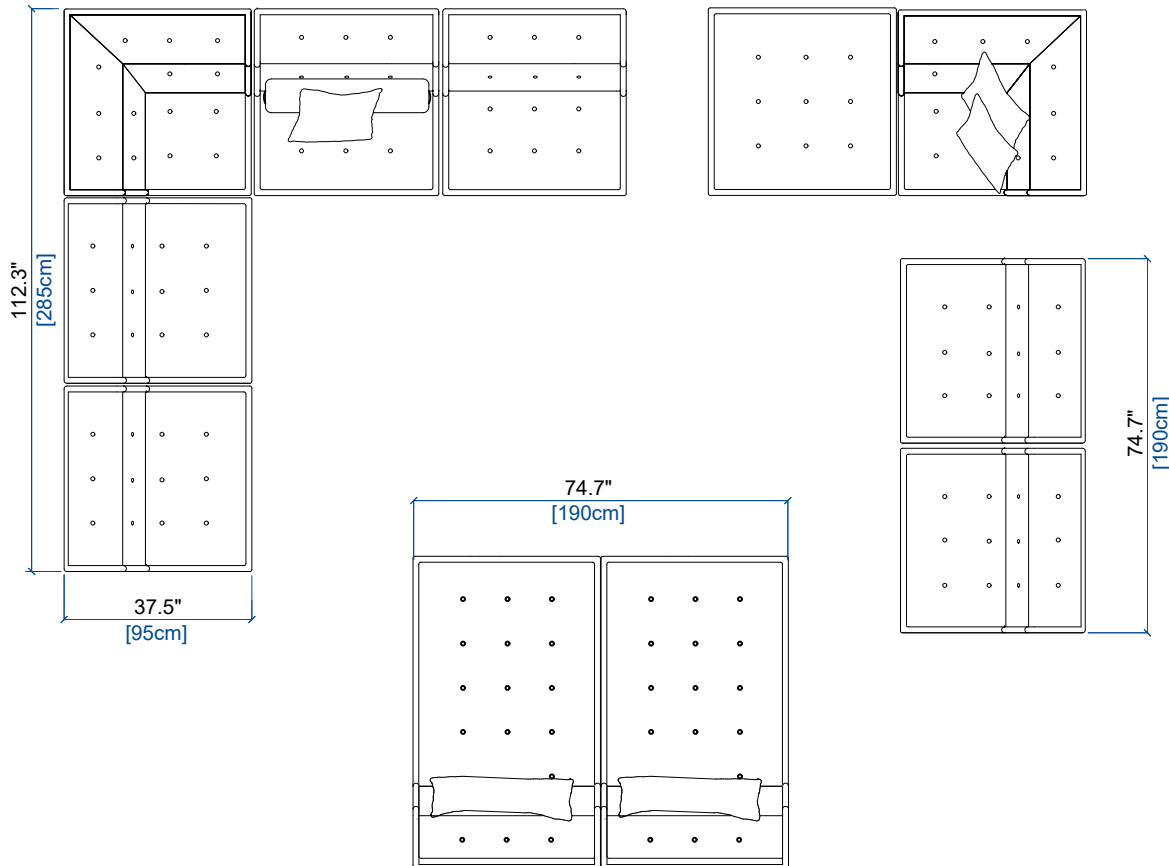

# MAH JONG

design Hans HOPFER

**rochebobo**  
PARIS



# MAH JONG

rochebobois  
PARIS

design Hans HOPFER

TISSUS DESIGN Kenzo Takada / FABRICS DESIGN Kenzo Takada / TELAS DISEÑO Kenzo Takada

COLLECTION NŌ GAKU – Harmonie Yoru / COLLECTION NŌ GAKU – Yoru Harmony / COLECCIÓN NŌ GAKU – Armonía Yoru

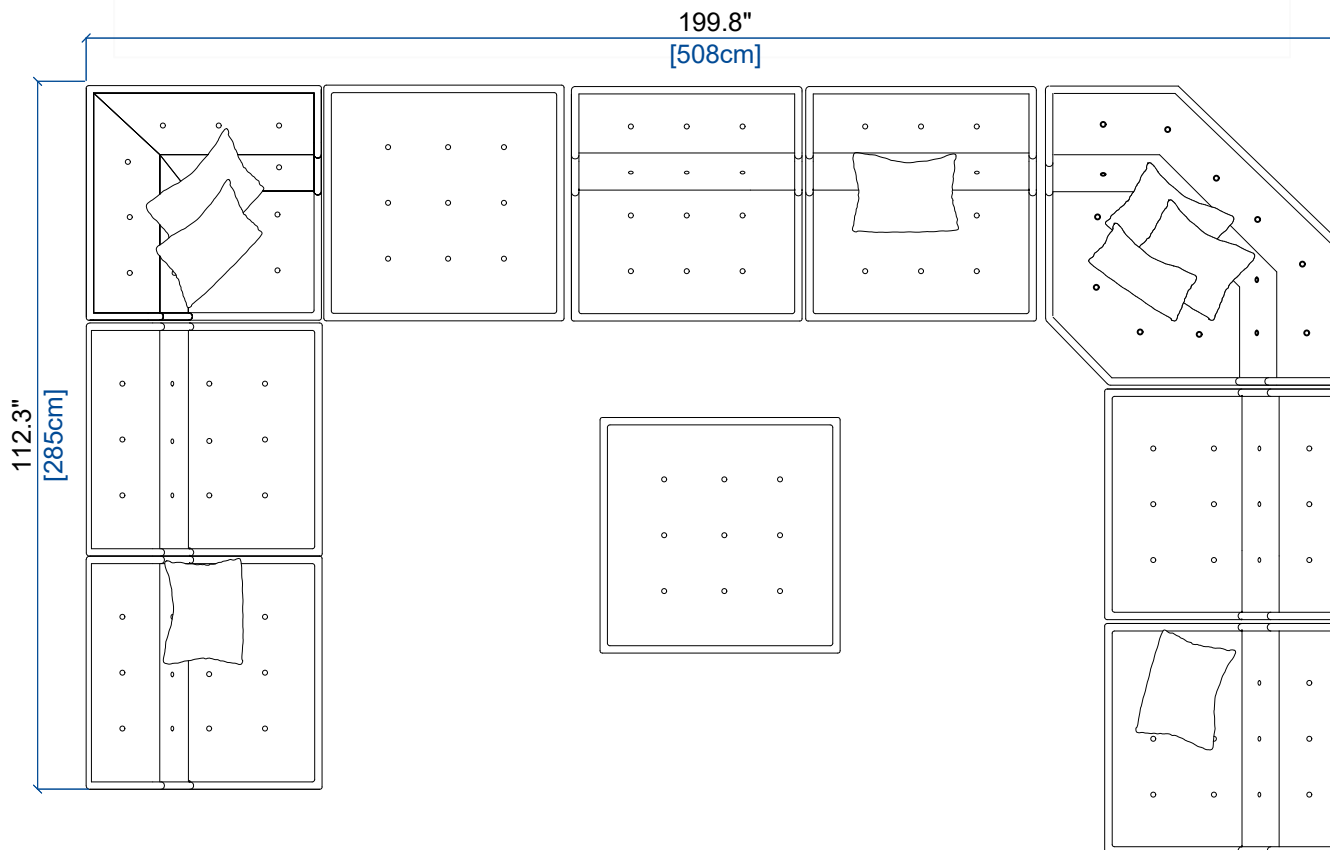

# MAH JONG

design Hans HOPFER

**rochebobo**  
PARIS



**TISSUS MISSONI HOME / MISSONI HOME FABRICS / TELA MISSONI HOME  
COLLECTION N°5 / COLLECTION N°5 / COLECCIÓN N°5**

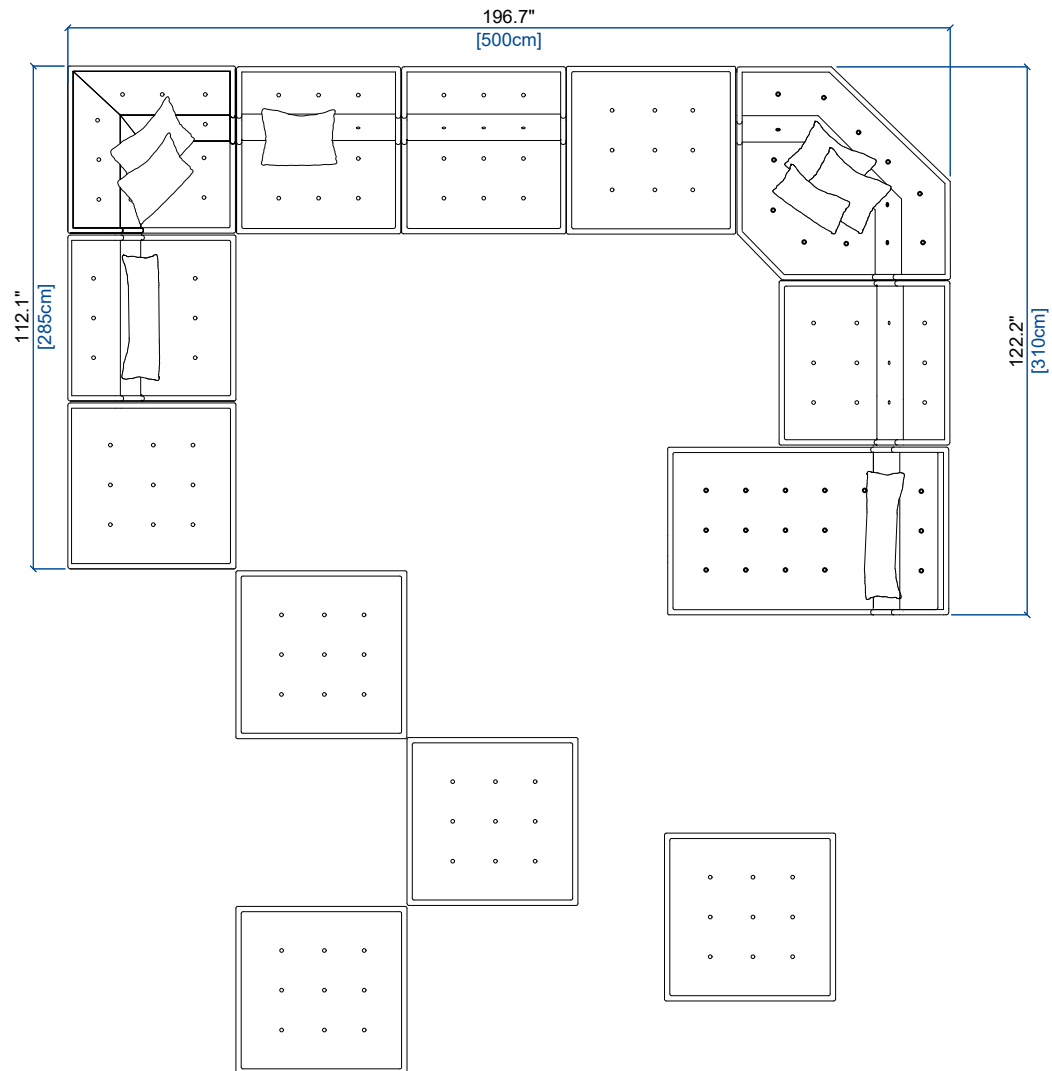

# MAH JONG

design Hans HOPFER

**rochebobo**  
PARIS



# MAH JONG

design Hans HOPFER

TISSUS JEAN PAUL GAULTIER / JEAN PAUL GAULTIER FABRICS / TELAS JEAN PAUL GAULTIER  
COLLECTION COUTURE / COUTURE COLLECTION / COLECCIÓN COUTURE

rochebobois  
PARIS

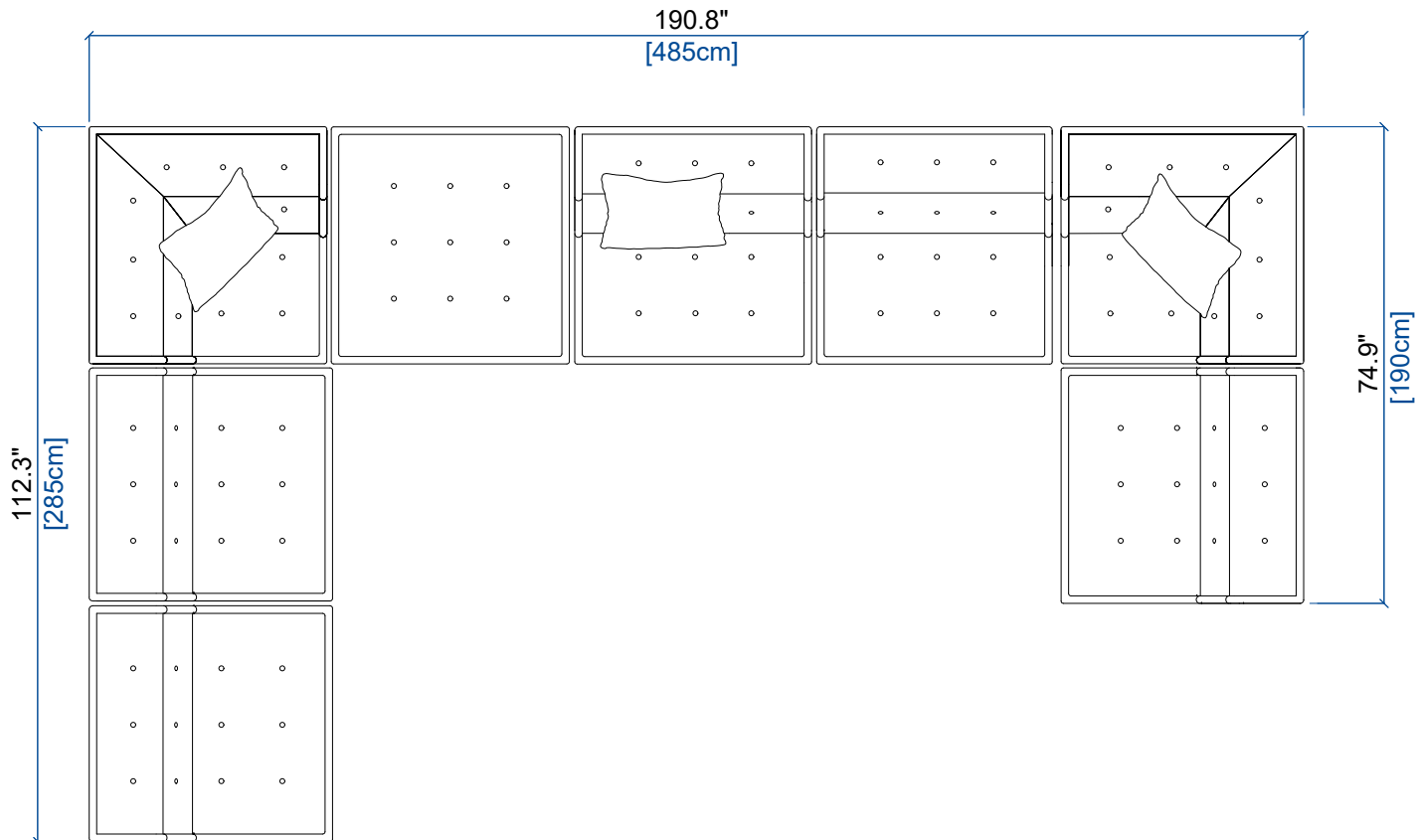



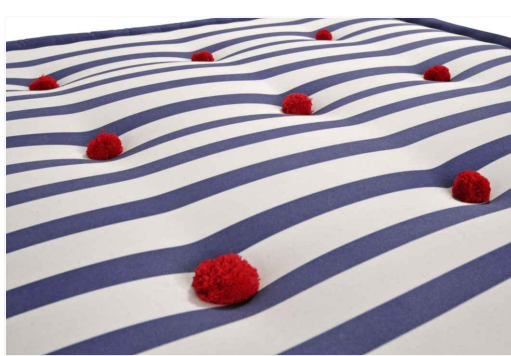

**INFORMATIONS TECHNIQUES / TECHNICAL SPECIFICATIONS / FICHA TECNICA :**

Structure dossier bois FSC : Sapin massif, multiplis de pin (CARB)  
 Coussin d'assise : Mousse polyuréthane Haute Résilience densité 37 kg/m<sup>3</sup> et ouate  
 Coussin dossier : Mousse polyuréthane Haute Résilience densité 18E et ouate  
 Petit coussin et Coussin cale-reins : Plumes et fibres (50% plumes et 50% fibres de polyester)

Back cushion structure FSC wood: Solid fir wood, pine plywood (CARB)  
 Seat cushion: High Resilience polyurethane foam density 37 kg/m<sup>3</sup> and cotton batting  
 Back cushion: High Resilience polyurethane foam density 18E and cotton batting  
 Small cushion and Lumbar cushion: Feathers and fibres (50% feathers and 50% polyester fibres)

Estructura respaldo madera FSC: Abeto macizo, multilaminado de pino (CARB)  
 Cojín de asiento: Espuma de poliuretano de alta resiliencia densidad 37 kg/m<sup>3</sup> y guata  
 Cojín de respaldo: Espuma de poliuretano de alta resiliencia densidad 18E y guata  
 Cojín pequeño y Cojín riñonera: Plumaz y fibras (50% plumaz y 50% fibras de poliéster)

**OBSERVATIONS / OBSERVATIONS / OBSERVACIONES :**

- Fabrication Européenne
- Modèle réalisable dans l'ensemble des revêtements de la collection ROCHE BOBOIS, à l'exception des cuirs d'épaisseur supérieure à 1,8 mm, du tissu Jersey et des tissus matelassés
- Système modulaire composable à l'infini à partir de coussins d'assise, de dossiers droits et d'angle et d'éléments chaise longue
- Tous les éléments sont capitonnés, matelassés et réalisés à la main
- L'assise d'angle panoramique ne peut être utilisée sans dossier à cause des coutures traversant l'assise. Elle peut cependant être utilisée en sous-assise
- Coutures faites à la main

- Manufactured in Europe
- Model available in all exclusive ROCHE BOBOIS materials, with the exception of leathers with thickness of more than 1.8mm, Jersey fabric and padded fabrics
- Modular system with endless combinations, including seat, straight and corner backs cushions and lounge chair units
- All elements are padded and stitched by hand
- The panoramic corner seat cushion cannot be used without a back cushion because of the stitching across the seat. However, it can be used as a seat bottom cushion
- Hand-made stitching

- Fabricación europea
- Modelo realizable en todas las telas y pieles de la colección ROCHE BOBOIS, excepto con pieles de un grosor superior a 1,8 mm, de la tela Jersey y de las telas acolchadas
- Sistema modular componible hasta el infinito a partir de cojines de asiento, de respaldo rectos y de ángulo, y elementos de chaise longue
- Todos los elementos son capitonés, acolchados y realizados a mano
- El asiento de ángulo panorámico no se puede utilizar sin respaldo a causa de las costuras que atraviesan el asiento. Sin embargo se puede utilizar en bajo asiento
- Costuras cosidas a mano

**OPTIONS / OPTIONAL / OPCIONES :**

- Plateformes en bois teinté ou laqué à commander auprès du fournisseur 321
- Tête relevable (mécanisme manuel) sur dossier droit
- Petit coussin
- Coussin cale-reins

- Stained or lacquered wooden platform to order from supplier 321
- Adjustable headrest (manual mechanism) for straight back cushion
- Small cushion
- Lumbar cushion

- Plataformas de madera tintada o lacada a pedir al proveedor 321
- Cabezal elevable (mecanismo manual) en el respaldo recto
- Cojín pequeño
- Cojín riñonera

# MAH JONG

design Hans HOPFER

rochebobois  
PARIS

ASSISE  
SEAT CUSHION  
COJIN DE ASIENTO

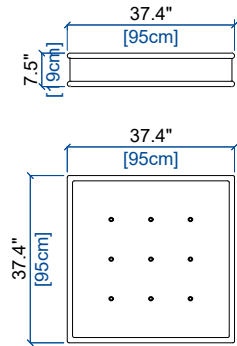

ASSISE CHAISE LONGUE  
LOUNGE CHAIR SEAT CUSHION  
ASIENTO CHAISE LONGUE

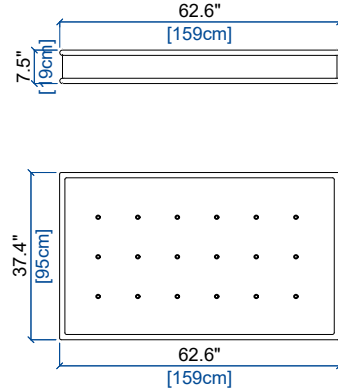

DOSSIER DROIT  
STRAIGHT BACK CUSHION  
COJIN DE RESPALDO RECTO

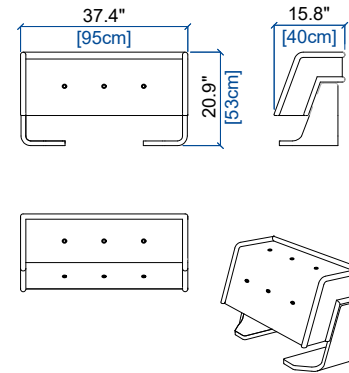

DOSSIER DROIT AVEC MECANISME  
STRAIGHT BACK CUSHION WITH MECHANISM  
COJIN DE RESPALDO CON MECANISMO

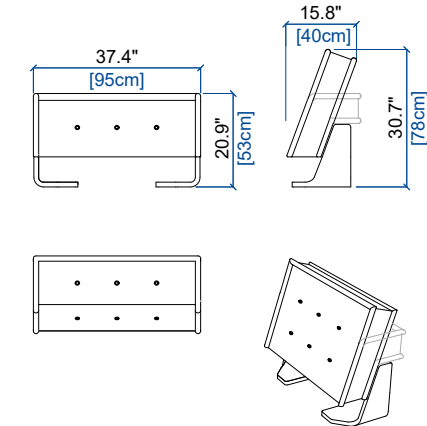

DOSSIER D'ANGLE  
BACK CORNER CUSHION  
COJIN DE RESPALDO DE ANGULO

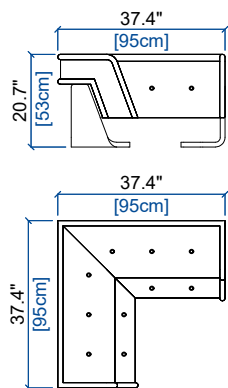

PETIT COUSSIN  
SMALL CUSHION  
COJIN PEQUEÑO

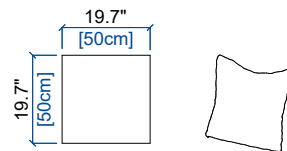

COUSSIN CALE-REIN  
LUMBAR CUSHION  
COJIN RIÑONERO

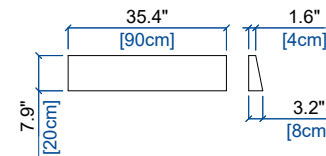

ATTACHE POUR DOSSIER  
BRACKET FOR BACKREST CUSHION  
UNION PARA COJIN DE RESPALDO

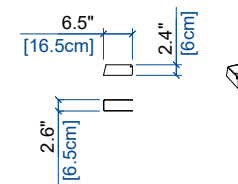

ASSISE D'ANGLE PANORAMIQUE  
PANORAMIC CORNER SEAT CUSHION  
ASIENTO PANORAMICO

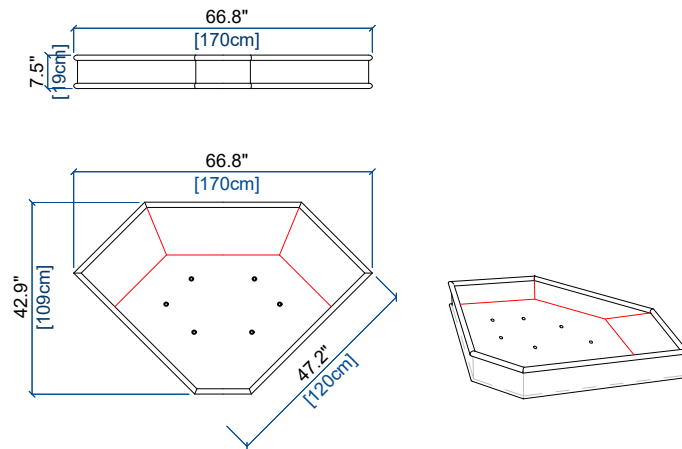

DOSSIER D'ANGLE PANORAMIQUE  
PANORAMIC CORNER BACK CUSHION  
RESPALDO DE ANGULO PANORAMICO

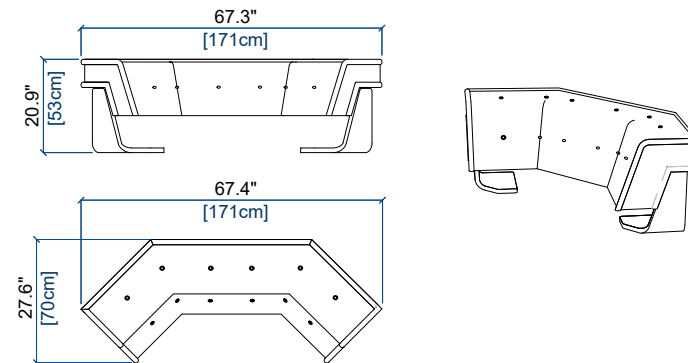

Coutures traversant l'assise / Stitching across the seat / Costuras que atraviesan el asiento